

SLM AP



MAGNET DRIVE CENTRIFUGAL PUMP SERIES SLM AP

ACC. TO API 685 2nd Edition



CENTRIFUGAL PUMP SERIES SLM AP ACC. TO API 685 2ND EDITION



This pump for refineries and the petro-chemical industry is the result of the continuous development of the proven Klaus Union centrifugal pumps with magnet drive and without shaft seal.

The Klaus Union pump type series SLM AP fulfills the high technical and economic demands that refineries and the petrochemical industry impose today on pumps without shaft seals. From a safety-engineering point of view, the SLM AP is an enhancement of the pumps with mechanical seal formerly utilised, which are described in the API 610 standard.

The construction type without shaft seal but with magnet drive guarantees that the pump is absolutely leak free, in accordance with the TA-Luft specification (German Technical Instruction on Air Quality Control), and nearly maintenance-free in operation, compared to the version with mechanical seal.

The leak-free pumps are particularly suitable for pumping toxic, aggressive, inflammable and other environmentally hazardous liquids in:



→ Refineries

→ On-/Offshore

→ Petrochemical

→ Chemical

Klaus Union pump series SLM AP covers the complete performance range of single-stage centrifugal pumps. Multi-Stage pumps and pumps constructed for high pressure operation are also available as special designs.

KLAUS UNION API 685 pumps offer significant advantages over conventional mechanically sealed (API 610) or other sealless canned motor designs:

- ▶ No dynamic seals / complete fluid containment (single/double containment possible)
- ▶ No ancillary seal supply systems
- ▶ Up to 450 °C (842 °F) pumped liquid temperature without cooling
- ▶ Standard motors or alternate drives in use/possible
- ▶ Full range of metallic and non-metallic containment shells available
- ▶ Several designs for handling liquids containing impurities (up to 20 % in weight)
- ▶ Close-coupled design available as well (API 685 para. 9.1.1.2)

Experience
Responsibility
Passion



Performance Range

- ▶ **Flow Rate:** Q = up to 3.500 m³/h
 - ▶ **Delivery Head:** H = up to 220 m L. C.
- Higher flow rates upon request

Pressure Ratings/Temperature Range

- ▶ **Flanges according to ANSI / ASME B16.5, Class 150, Class 300**
 - ▶ **Temperature Range:** -120 °C up to 450 °C
- Higher pressure ratings upon request

Materials as in the standard (API 685 Appendix H)

Components	S-8l
Pump Casing	Carbon Steel
Impeller	316 Austenite
Wetted Parts	316 Austenite
Containment Shell	Hastelloy C
Pump Shaft	316 Austenite
Intermediate Lantern / Bearing Support	Carbon Steel
Drive Shaft	Carbon Steel

Other Materials upon Request (A-8, H-1, H-2, T-1, D-1, A-9)

Quality Assurance

A major component of the Klaus Union ethos is to ensure highest product quality. Existing quality assurance procedures with Klaus Union suppliers are constantly monitored from order placement to goods receipt and final assembly. This quality assurance system, developed on latest technologies, complies with the requirements of international regulations.

Klaus Union is a DIN EN ISO 9001 certified company



In accordance with TÜV NORD CERT procedures,

KLAUS UNION GmbH & Co. KG
Blumenfeldstraße 18, 44795 Bochum
&
KLAUS UNION Service GmbH & Co. KG
Blumenfeldstraße 18, 44795 Bochum

are certified according to
DIN EN ISO 9001

DESIGN DETAILS

SERIES SLM AP

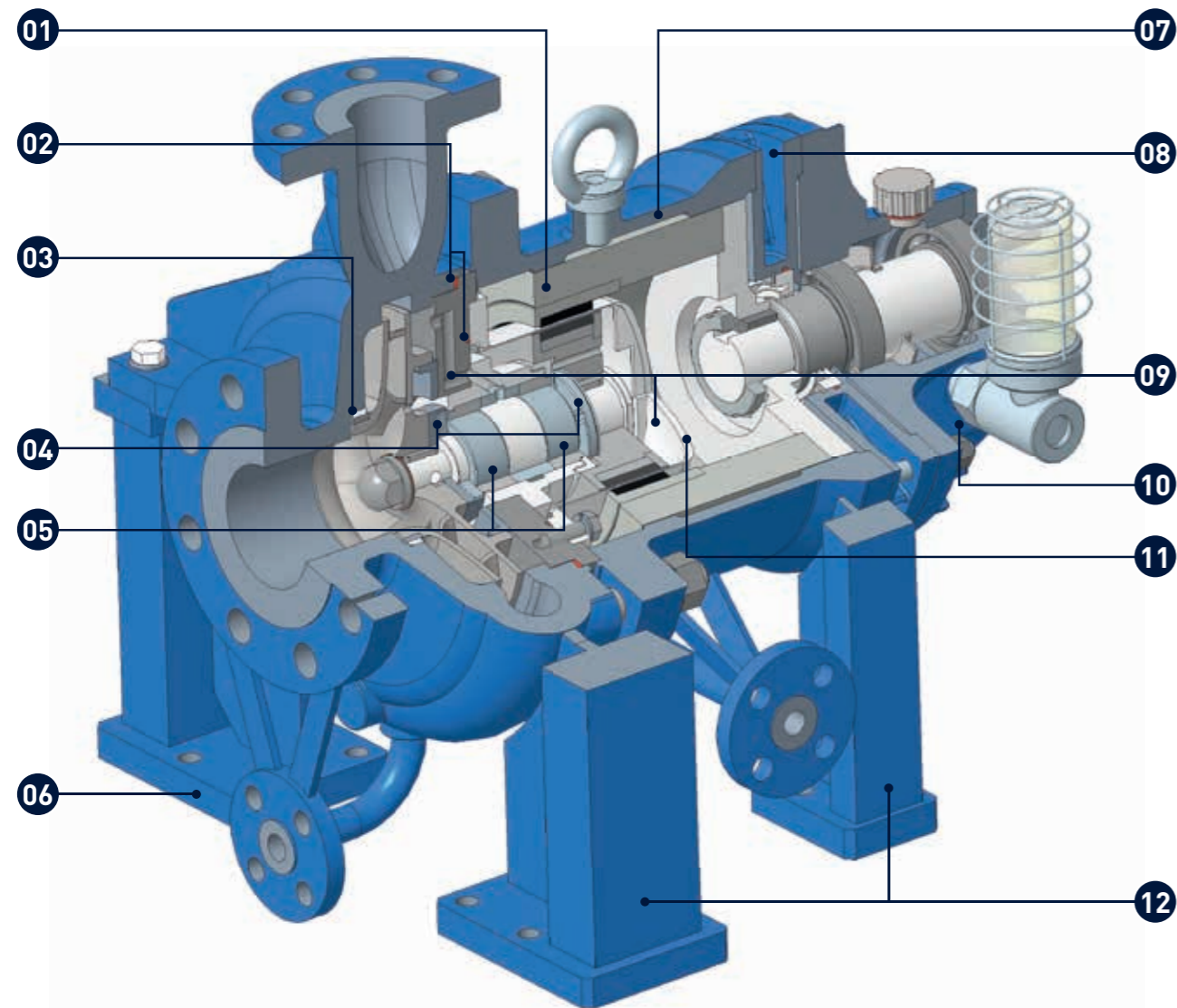

Please see
the description
on the following page
→

Design According to API 685 2nd Edition

- 01 ▶ **Outer Magnet Carrier (API 685 § 9.1.3.3)**
With additional Mechanical Rub Ring.
- 02 ▶ **Gasket (API 685 § 6.2.7)**
On the Containment Shell placed in Shunt.
- 03 ▶ **Wear Rings (API 685 § 6.6)**
Replaceable on the Impeller and in the Casing.
- 04 ▶ **Thrust Bearing (API 685 § 6.9)**
Hydraulic measures reduce Axial Thrust Load over the complete Performance Range.
- 05 ▶ **Journal Bearing (API 685 § 6.9)**
Double Bearing made of Silicon Carbide (SSiC); counter centered Combination for Universal Utilisation.
- 06 ▶ **Casing Drain (API 685 § 6.3.3)**
With Flanged Connection.
- 07 ▶ **Intermediate Lantern (API 685 § 9.1.3.3 / 9.1.3.5)**
With Magnet Drive Rub Ring and Assembly / Disassembly Guidance.
- 08 ▶ **Thermal Barrier**
Lowers the Sump Oil Temperature and thus increases the Working Life of the Sump Oil and Anti-Friction Bearings.
- 09 ▶ **Flushing System (API 685 § 6.1.9)**
Pressurized over the entire Operating Range.
- 10 ▶ **Bearing Support (API 685 § 9.1.4)**
Oil Lubrication with Labyrinth Sealing and constant level oiler.
- 11 ▶ **Labyrinth Sealing**
Single Containment Shell, Labyrinth Sealing and Intermediate Lantern with Flanged Drain Connection.
Optional: Backup Mechanical Seal and Leakage Monitoring (Secondary Control System; § 3.66);
Optional: Double Containment Shell with Pressure Monitoring (Secondary Containment System; § 3.68).
- 12 ▶ **Casing and Intermediate Lantern (API § 6.2.9)**
Centerline Support (available as an option).

THE MODULAR SYSTEM FOR SEALLESS CENTRIFUGAL PUMPS

Pump Casing

The design of pump casings have been calculated with the help of the finite element method (FEM) for minimum 40 bar internal pressure at 120 °C and a nozzle load corresponding to double the values specified in API 685 2nd Edition. The corrosion allowance of 3 mm stipulated according to API 685 § 6.2.5 has been taken into consideration. The flange connections are designed according to ANSI/ASME B16.5, Class 300.

Von Mises Tension (Maximum)
Averaged Values
Original Models
Combination
Principal Units
mmNs)

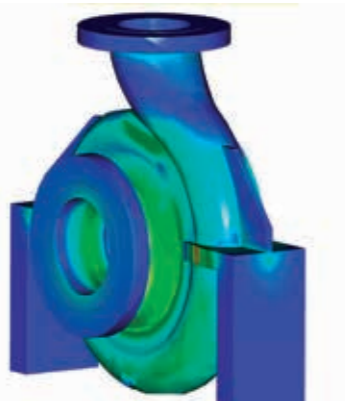
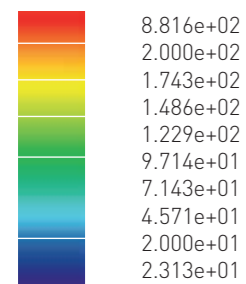
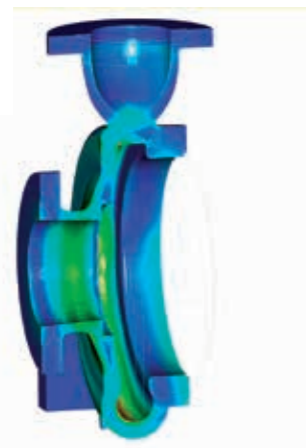
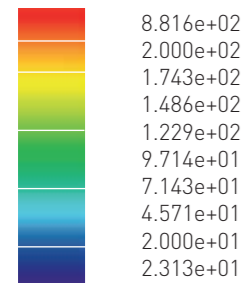

Journal Bearings as per API 685 § 6.9

The thrust and radial journal bearings are self-lubricated and in the standard design consist of pure sintered silicon carbide (SSiC). The journal bearings components are fixed and secured in both the axial and radial directions. Compensation for the different thermal expansion coefficients of the metallic and ceramic components is ensured by the constructional design.

The pressurised flush flow for lubrication and cooling of the journal bearings is taken from a high pressure area inside the hydraulic system and fed directly into the journal bearings (see Fig. 1). A dry-run-capability of the journal bearings is available as option.

Magnet Drive as per API 685 § 9.1.3./6.1.9

The magnet drive is configured concentrically and transmits torque without slip via the field of the permanent magnets. The thermally stable samarium-cobalt material (Sm2Co17) withstands operating temperatures of up to 400 °C without cooling.

A second pressurised flush flow is taken off at a high pressure area in the hydraulic system and fed to the magnet drive, where it provides for the necessary heat dissipation. The pressurised flush flow ensures that the temperature rise in the containment shell area does not lead to evaporation of the pumped liquid (see Fig. 2).



Options for every Requirement

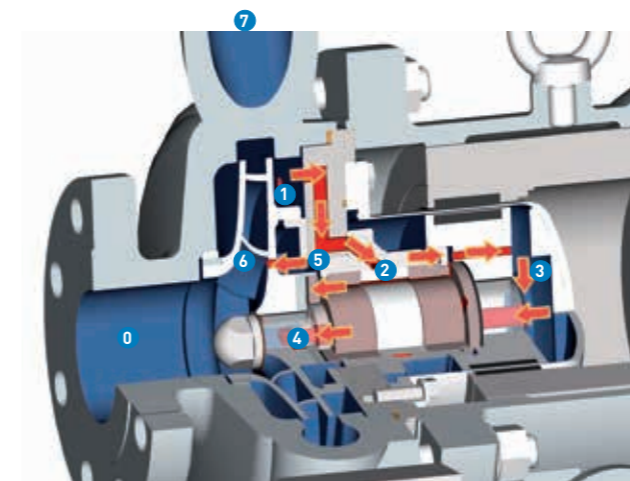

Fig. 1. Pressure / Temperature Profile / Journal Bearing Flush Flow

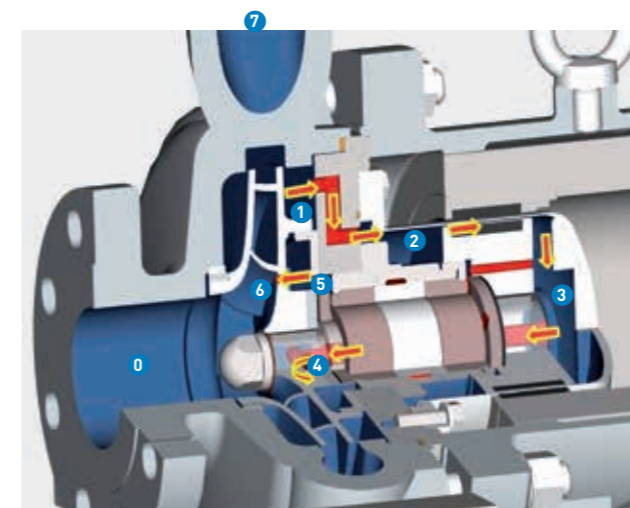
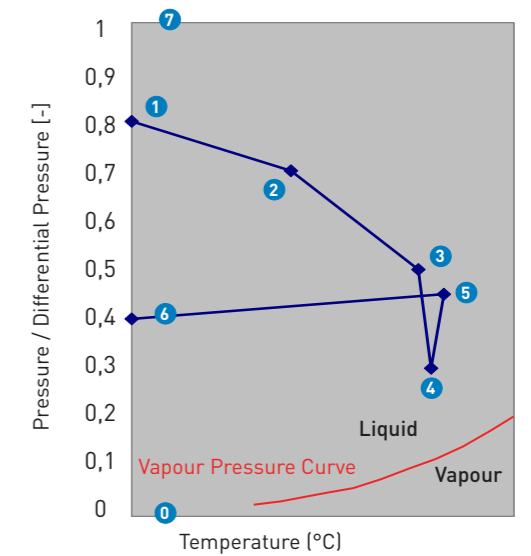
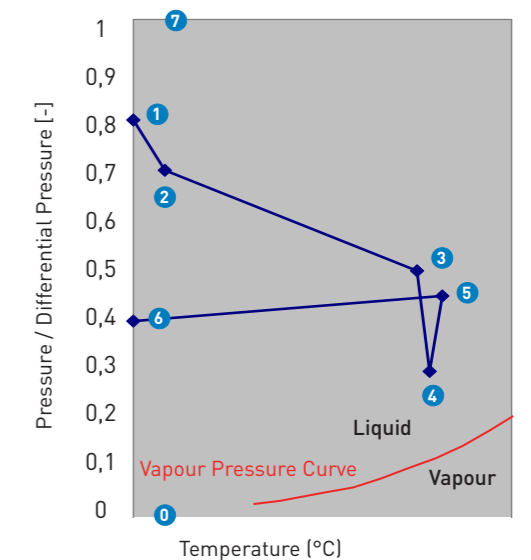

Fig. 2. Pressure / Temperature Profile / Containment Shell Flush Flow



STANDARDS AND OPTIONAL PACKAGES ACC. TO API 685 2ND EDITION

Klaus Union Standard

Single Containment Shell with Drain at the Intermediate Lantern

The standard version of the SLM AP pump is equipped with a single containment shell.

The intermediate lantern is equipped with a labyrinth system to the atmosphere and a drain connection (D2). A pressure gauge or a liquid sensor can be utilized as a leakage detector.

Close-Coupled Design

The close-coupled design offers significant cost savings because of the following advantages:

- ▶ No alignment between pump and motor
- ▶ No coupling and coupling guard
- ▶ No ball bearings
 - Pump completely free of scheduled maintenance
 - No oil lubrication necessary
 - Lower noise level
- ▶ High stiffness of the pump shaft because of small overhung compared to API 610 pumps
- ▶ Use of standard high efficient IEC and NEMA motors contrary to canned motors
 - Better availability with standard motors
 - Maintenance of motors is standardized and can be done by the customer on site
- ▶ Base plates for close-coupled design do not need to be rigid acc. to API 685 - 7.3

Optional Packages

Centerline mounting

- ▶ Different baseplate
- ▶ Different mounting of lantern and casing

Dry Run Capability

- ▶ Non metallic containment shell, preferred ceramic shell
- ▶ Slide bearing with „RTZ“ design
- ▶ Load controller to detect dry run condition or run-away condition (JE)
- ▶ Customer to advice in order to add liquid sensor in suction line



Fig. 4. Pump in Close-Coupled Design Series SLM APC



Options for every **Requirement**

Secondary Containment System as per API 685 § 3.68 (PE + TE3)

- ▶ Double containment shell
- ▶ Monitoring device on containment shell manifold, pressure sensor (PE)
- ▶ No second shell connection, as flushing of shells can be achieved by pressing flush liquid into manifold and will drain into the inner shell
- ▶ Drain hole in intermediate lantern plugged (welded or threaded)
- ▶ TPX Temperature monitoring system (TE3)

Secondary Control as per API 685 § 3.65 (JE + LE1 + D2)

- ▶ Single containment shell
- ▶ Pump power monitoring (JE)
- ▶ Liquid detection in vertical section of the discharge piping system (LE1)
- ▶ Secondary, welded drain connection on intermediate lantern with flange/ blinded backup bearing seal on drive shaft (D2)
- ▶ Backup mechanical seal on drive shaft

Secondary Control System as per API 685 § 3.66 with Liquid Sensor (LE2)

- ▶ Welded drain connection on intermediate lantern with flange/blinded
- ▶ 3-way adapter on drain connection
- ▶ Backup mechanical seal on drive shaft
- ▶ Monitoring device, liquid detector (LE2)

Secondary Control System as per API 685 § 3.66 with Pressure Sensor (PE)

- ▶ Welded drain connection on intermediate lantern with flange/blinded
- ▶ 3-way adapter on drain connection
- ▶ Backup mechanical seal on drive shaft
- ▶ Monitoring device, pressure transmitter (PE)

Basic Monitoring (TE3 + JE)

- ▶ TPX Temperature monitoring system (TE3)
- ▶ Load controller (JE)

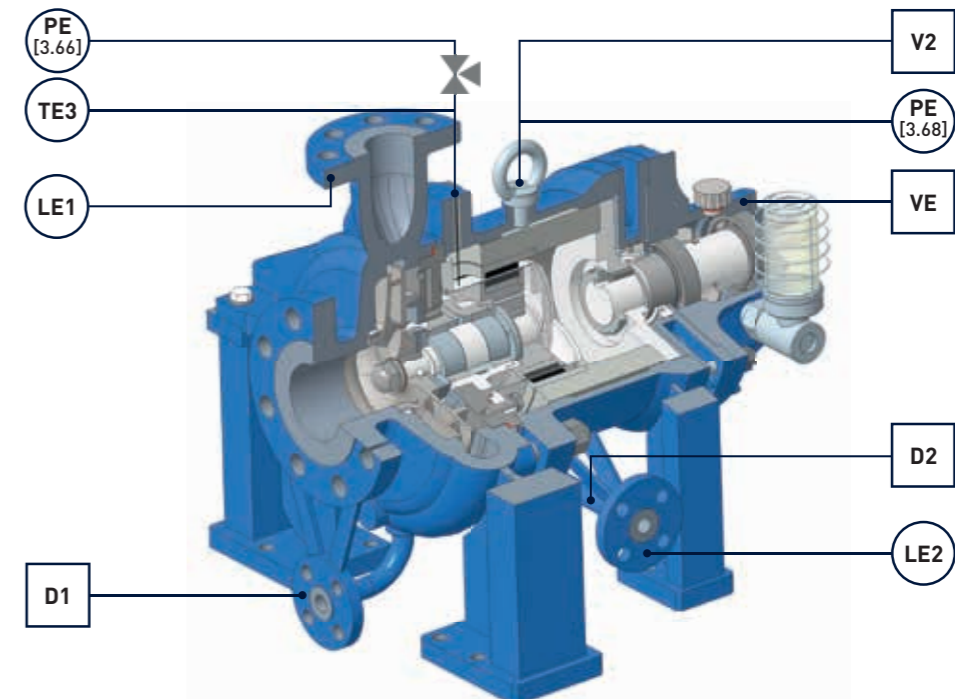

Fig. 4. P+ID of SLM AP

Product Range Pumps:

Pumps with Magnet Drive

- ▶ Centrifugal Pumps acc. to DIN EN ISO 2858 & DIN EN ISO 15783, SLM NV
- ▶ Centrifugal Pumps acc. to ASME B73.3M, SLM AV
- ▶ Centrifugal Pumps for Petrochemical Applications acc. to API 685, SLM APL / SLM APC
- ▶ Centrifugal Pumps for High Pressure Applications, SLM SV/SLM GV
- ▶ Centrifugal Pumps for High Temperature Applications, SLM NHO
- ▶ Self-Priming Centrifugal Pumps, SLM SV
- ▶ Multi-Stage Centrifugal Pumps, Tension-Rod or Barrel-Type Design, SLM GV
- ▶ Submerged Centrifugal Pumps, SLM NVT
- ▶ Twin Screw Pumps acc. API 676, SLM DSP-2C

Pumps with Shaft Sealing

- ▶ Centrifugal Pumps acc. to DIN EN ISO 2858 & DIN EN ISO 5199, NOV
- ▶ Multi-Stage Centrifugal Pumps, Tension-Rod or Barrel-Type Design, GOV / GOVT
- ▶ Horizontal and Vertical Propeller Pumps, P
- ▶ Bottom-Flange Propeller Pumps, UP
- ▶ Submerged Centrifugal Pumps, TP NO
- ▶ Submerged, Multi-Stage Centrifugal Pumps, TP GO
- ▶ Twin Screw Pumps acc. API 676, DSP-2C / DSP-4C

Product Range Valves:

- ▶ Globe Valves, T
- ▶ Globe Valves, Y
- ▶ Control Valves
- ▶ Gate Valves, Isomorphous Construction Series
- ▶ Gate Valves, Wedge or Wedge Plates
- ▶ Relief Valves
- ▶ Check Valves
- ▶ Sight Glasses
- ▶ Strainers
- ▶ Filters
- ▶ Bottom Valves
- ▶ Safety Valves

Klaus Union Service Performance:

- ▶ Workshop / On-Site Repairs
- ▶ Genuine Spare Part Delivery Worldwide
- ▶ Spare Parts Storage
- ▶ Customized Spare Parts Management
- ▶ On-Site Maintenance
- ▶ Installation
- ▶ Retrofitting
- ▶ On-Site Testing / Monitoring
- ▶ Customer Advisory Service
- ▶ Start Up & Commissioning
- ▶ Individual 24 / 7-Service
- ▶ Trouble-Shooting
- ▶ In-House & On-Site Training
- ▶ On-Site Assembly and Disassembly
- ▶ Long-Term Maintenance Contracts
- ▶ Maintenance Planning and Consulting
- ▶ Diagnostics

Klaus Union GmbH & Co. KG

Blumenfeldstraße 18 | 44795 Bochum | Germany

Phone: +49 (0) 234 4595-0 | Fax: +49 (0) 234 4595-7000 | E-Mail: info@klaus-union.com

www.klaus-union.com